

High Luminous Efficacy  
RGB LED Emitter  
**LZ4-00MC10**

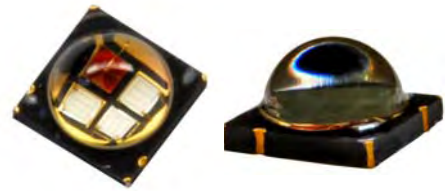

## Key Features

- High Luminous Efficacy 10W RGB LED
- Individually addressable die
- Unlimited color mixing
- Ultra-small foot print – 7.0mm x 7.0mm x 4.3mm
- Surface mount ceramic package with integrated glass lens
- Very low Thermal Resistance (2.7°C/W)
- Very high Luminous Flux density
- New industry standard for Lumen Maintenance (>90% at 100,000 Hours)
- JEDEC Level 2 for Moisture Sensitivity Level
- Autoclave complaint (JEDEC JESD22-A102-C)
- Lead (Pb) free and RoHS compliant
- Reflow solderable (up to 6 cycles)
- Emitter available on [Standard MCPCB](#) (optional)

## Typical Applications

- Architectural Lighting
- Entertainment
- Stage and Studio Lighting
- Accent Lighting
- Medical Illumination
- Microscope Illumination
- Full Color Displays

## Description

The LZ4-00MC10 RGB LED emitter contains one red, two green, and one blue LED die which provides 10W power in an extremely small package. With a 7.0mm x 7.0mm x 4.3mm ultra-small footprint, this package provides exceptional luminous flux density. LedEngin's RGB LED offers ultimate design flexibility with individually addressable die. The patent-pending design has unparalleled thermal and optical performance. The high quality materials used in the package are chosen to optimize light output and minimize stresses which results in monumental reliability and lumen maintenance. The robust product design thrives in outdoor applications with high ambient temperatures and high humidity.

## Table of Contents

Product Nomenclature . . . . .	3
IPC/JEDEC Moisture Sensitivity . . . . .	3
Average Lumen Maintenance Projections . . . . .	3
Luminous Flux Binning. . . . .	4
Dominant Wavelength Binning . . . . .	4
Forward Voltage Binning . . . . .	4
Absolute Maximum Ratings . . . . .	5
Optical Characteristics . . . . .	5
Electrical Characteristics . . . . .	5
Mechanical Dimensions . . . . .	6
Pin-Out . . . . .	6
Recommended Solder Pad Layout . . . . .	6
Reflow Soldering Profile . . . . .	7
Typical Radiation Pattern . . . . .	8
Typical Relative Spectral Power Distribution . . . . .	8
Typical Dominant Wavelength Shift . . . . .	9
Typical Dominant Wavelength Shift over Temperature . . . . .	9
Typical Relative Light Output . . . . .	10
Typical Relative Light Output over Temperature . . . . .	10
Typical Forward Current Characteristics . . . . .	11
Current Derating Curves . . . . .	11
Emitter Tape & Reel Specifications . . . . .	12
Company Information . . . . .	13

## Product Nomenclature

The LZ Series base part number designation is defined as follows:

L Z A – B C D E F G

Where:

- A – designates the number of LED die in the package (“4” for 10W)
- B – designates the package level (“0” for Emitter)
- C – designates the radiation pattern (“0” for Lambertian)
- D and E – designate the color (“MC” for “RGGB” Mixed Dice)
- F and G – designate the Power (“10” for 10W typical rating)

Ordering information:

For ordering LedEngin products, please reference the base part number above. The base part number represents any of the flux or dominant wavelength bins specified in the binning tables below. For ordering products with special bin selections, please contact a LedEngin sales representative or authorized distributor.

## IPC/JEDEC Moisture Sensitivity Level

Table 1 - IPC/JEDEC J-STD-20 MSL Classification:

Level	Soak Requirements					
	Floor Life		Standard		Accelerated	
	Time	Conditions	Time (hrs)	Conditions	Time (hrs)	Conditions
2	1 Year	≤ 30°C/ 60% RH	168 +5/-0	85°C/ 60% RH	n/a	n/a

Notes for Table 1:

1. The standard soak time is the sum of the default value of 24 hours for the semiconductor manufacturer’s exposure time (MET) between bake and bag and the floor life of maximum time allowed out of the bag at the end user of distributor’s facility.

## Average Lumen Maintenance Projections

Lumen maintenance generally describes the ability of a lamp to retain its output over time. The useful lifetime for solid state lighting devices (Power LEDs) is also defined as Lumen Maintenance, with the percentage of the original light output remaining at a defined time period.

Based on long-term WHTOL testing, LedEngin projects that the LZ Series will deliver, on average, 90% Lumen Maintenance at 100,000 hours of operation at a forward current of 700 mA. This projection is based on constant current operation with junction temperature maintained at or below 125°C.

## Luminous Flux Bins

Table 2:

Bin Code	Minimum			Maximum			Typical		
	Luminous Flux ( $\Phi_V$ )			Luminous Flux ( $\Phi_V$ )			Luminous Flux ( $\Phi_V$ )		
	@ $I_F = 700\text{mA}$ <sup>[1,2]</sup>			@ $I_F = 700\text{mA}$ <sup>[1,2]</sup>			@ $I_F = 1000\text{mA}$ <sup>[1,2]</sup>		
	(lm)			(lm)			(lm)		
	1 Red	2 Green	1 Blue	1 Red	2 Green	1 Blue	1 Red	2 Green	1 Blue
J	60			75			85		
K	75			93			105		
P		186			234			270	
Q		234			292			320	
E			24			31			35
F			31			38			45

Notes for Table 2:

- Luminous flux performance guaranteed within published operating conditions. LedEngin maintains a tolerance of  $\pm 10\%$  on flux measurements.
- Future products will have even higher levels of radiant flux performance. Contact LedEngin Sales for updated information.

## Dominant Wavelength Bins

Table 3:

Bin Code	Minimum			Maximum		
	Dominant Wavelength ( $\lambda_D$ )			Dominant Wavelength ( $\lambda_D$ )		
	@ $I_F = 700\text{mA}$ <sup>[1,2]</sup>			@ $I_F = 700\text{mA}$ <sup>[1,2]</sup>		
	(nm)			(nm)		
	1 Red	2 Green <sup>[2]</sup>	1 Blue	1 Red	2 Green <sup>[2]</sup>	1 Blue
R2	620			630		
G1		515			520	
G2		520			525	
B4			455			460
B5			460			465
B6			465			470

Notes for Table 3:

- LedEngin maintains a tolerance of  $\pm 0.5\text{nm}$  on dominant wavelength measurements.
- Green LEDs are binned for dominant wavelength @  $I_F = 350\text{mA}$ . Refer to Figure 6 for typical dominant wavelength shift over forward current.

## Forward Voltage Bin

Table 4:

Bin Code	Minimum			Maximum		
	Forward Voltage ( $V_F$ )			Forward Voltage ( $V_F$ )		
	@ $I_F = 700\text{mA}$ <sup>[1,2]</sup>			@ $I_F = 700\text{mA}$ <sup>[1,2]</sup>		
	(V)			(V)		
	1 Red	2 Green <sup>[2]</sup>	1 Blue	1 Red	2 Green <sup>[2]</sup>	1 Blue
0	2.24	6.40	3.20	3.20	8.80	4.16

Notes for Table 4:

- LedEngin maintains a tolerance of  $\pm 0.04\text{V}$  on forward voltage measurements for the Red and Blue LEDs.
- For binning purposes, Forward Voltage for Green is binned with both LED dice connected in series. LedEngin maintains a tolerance of  $\pm 0.08\text{V}$  on forward voltage measurements for the two Green LEDs.

## Absolute Maximum Ratings

Table 5:

Parameter	Symbol	Value	Unit
DC Forward Current <sup>[1]</sup>	$I_F$	1000	mA
Peak Pulsed Forward Current <sup>[2]</sup>	$I_{FP}$	1500	mA
Reverse Voltage	$V_R$	See Note 3	V
Storage Temperature	$T_{stg}$	-40 ~ +150	°C
Junction Temperature	$T_J$	150	°C
Soldering Temperature <sup>[4]</sup>	$T_{sol}$	260	°C
Allowable Reflow Cycles		6	
Autoclave Conditions <sup>[5]</sup>		121°C at 2 ATM, 100% RH for 168 hours	
ESD Sensitivity <sup>[6]</sup>		> 8,000 V HBM Class 3B JESD22-A114-D	

Notes for Table 5:

- Maximum DC forward current is determined by the overall thermal resistance and ambient temperature. Follow the curves in Figure 11 for current derating.
- Pulse forward current conditions: Pulse Width  $\leq$  10msec and Duty Cycle  $\leq$  10%.
- LEDs are not designed to be reverse biased.
- Solder conditions per JEDEC 020D. See Reflow Soldering Profile Figure 3.
- Autoclave Conditions per JEDEC JESD22-A102-C.
- LedEngin recommends taking reasonable precautions towards possible ESD damages and handling the LZ4-00MC10 in an electrostatic protected area (EPA). An EPA may be adequately protected by ESD controls as outlined in ANSI/ESD S6.1.

## Optical Characteristics @ $T_C = 25^\circ\text{C}$

Table 6:

Parameter	Symbol	Typical			Unit
		1 Red	2 Green	1 Blue <sup>[1]</sup>	
Luminous Flux (@ $I_F = 700\text{mA}$ )	$\Phi_V$	85	230	30	lm
Luminous Flux (@ $I_F = 1000\text{mA}$ )	$\Phi_V$	115	280	40	lm
Dominant Wavelength <sup>[2,3,4]</sup>	$\lambda_D$	625	520	460	nm
Viewing Angle <sup>[5]</sup>	$2\Theta_{\frac{1}{2}}$		95		Degrees
Total Included Angle <sup>[6]</sup>	$\Theta_{0.9}$		115		Degrees

Notes for Table 6:

- When operating the Blue LED, observe IEC 60825-1 class 2 rating. Do not stare into the beam.
- Red and Blue dominant wavelength @  $I_F = 700\text{mA}$ . Green dominant wavelength @  $I_F = 350\text{mA}$ .
- Refer to Figure 6 for typical dominant wavelength shift over forward current.
- Refer to Figure 7 for typical dominant wavelength shift over temperature.
- Viewing Angle is the off axis angle from emitter centerline where the luminous intensity is  $\frac{1}{2}$  of the peak value.
- Total Included Angle is the total angle that includes 90% of the total luminous flux.

## Electrical Characteristics @ $T_C = 25^\circ\text{C}$

Table 7:

Parameter	Symbol	Typical			Unit
		1 Red	2 Green	1 Blue	
Forward Voltage (@ $I_F = 700\text{mA}$ )	$V_F$	2.4	7.2	3.5	V
Forward Voltage (@ $I_F = 1000\text{mA}$ )	$V_F$	2.6	7.5	3.7	V
Temperature Coefficient of Forward Voltage	$\Delta V_F/\Delta T_J$	-1.9	-5.8	-3.0	mV/°C
Thermal Resistance (Junction to Case)	$R\Theta_{J-C}$		2.7		°C/W

## Mechanical Dimensions (mm)

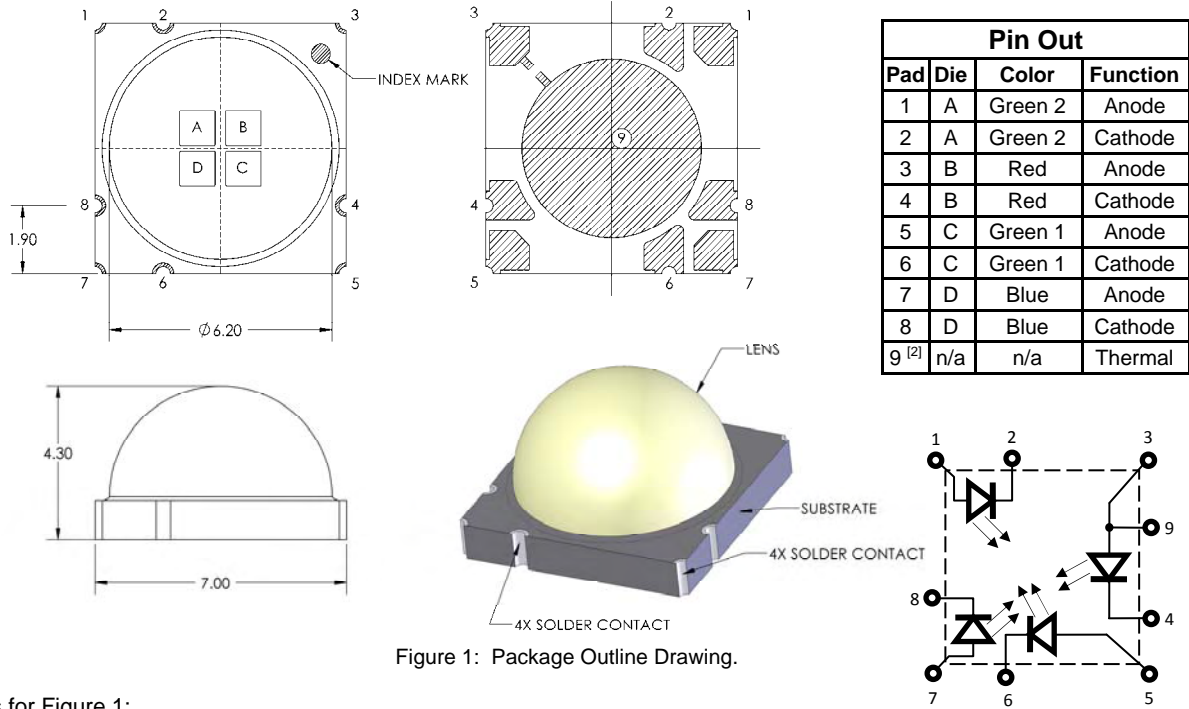

Figure 1: Package Outline Drawing.

Notes for Figure 1:

1. Unless otherwise noted, the tolerance =  $\pm 0.20$  mm.
2. Thermal contact, Pad 9, is electrically connected to Pad 3. Do not connect any pad to the thermal contact, Pad 9. When mounting the LZ4-00MC10 onto a MCPCB, by default its dielectric layer provides for the necessary electrical insulation in between all contact pads. LedEngin offers a [LZ4-20MC10](#) MCPCB option which provides for electrical insulation between all contact pads. Please refer to Application Note MCPCB Option 2, or contact a LedEngin sales representative for more information.

## Recommended Solder Pad Layout (mm)

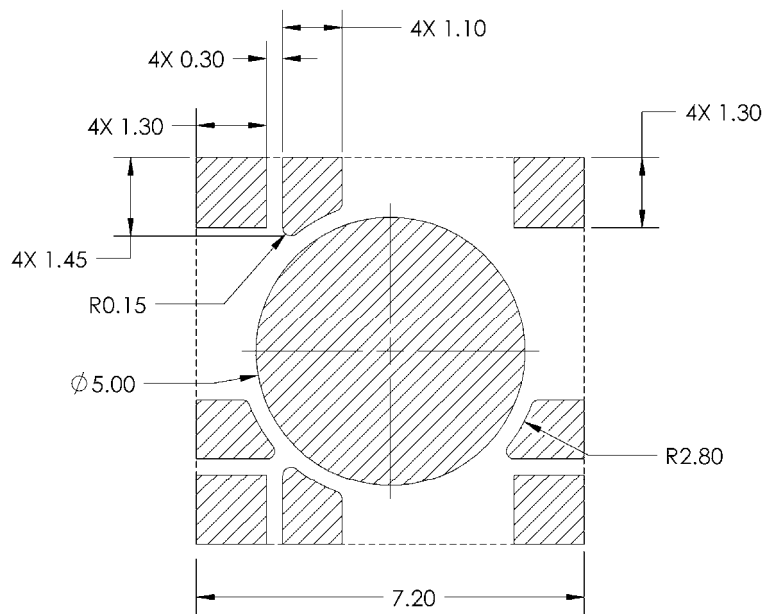

Figure 2: Recommended solder mask opening (hatched area) for anode, cathode, and thermal pad.

Note for Figure 2:

1. Unless otherwise noted, the tolerance =  $\pm 0.20$  mm.

## Reflow Soldering Profile

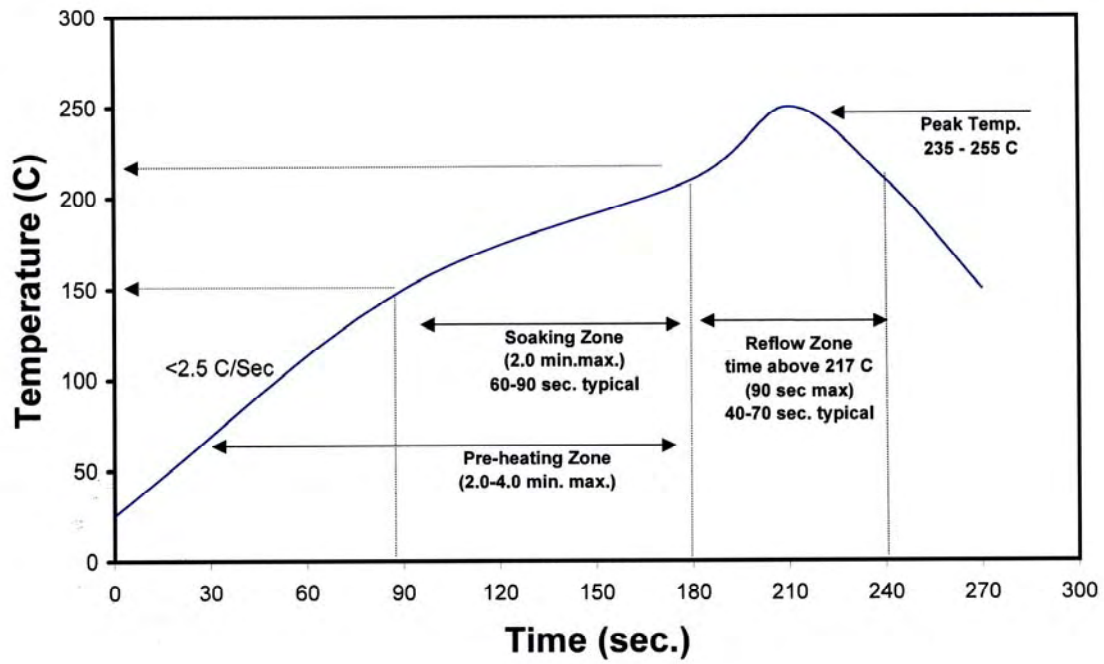

Figure 3: Reflow soldering profile for lead free soldering.

## Typical Radiation Pattern

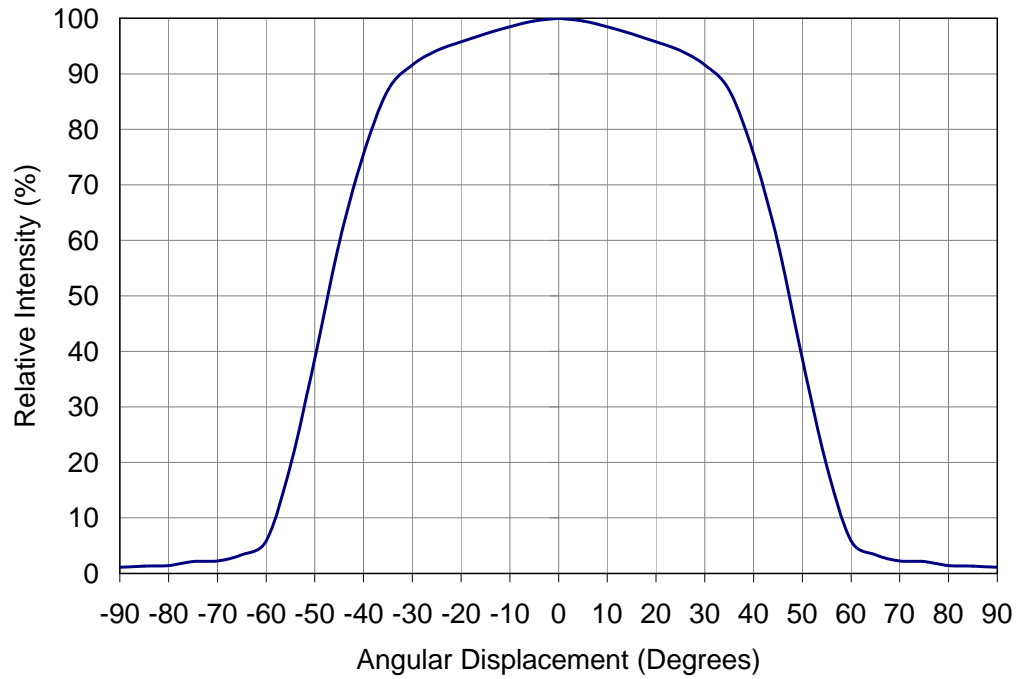

Figure 4: Typical representative spatial radiation pattern.

## Typical Relative Spectral Power Distribution

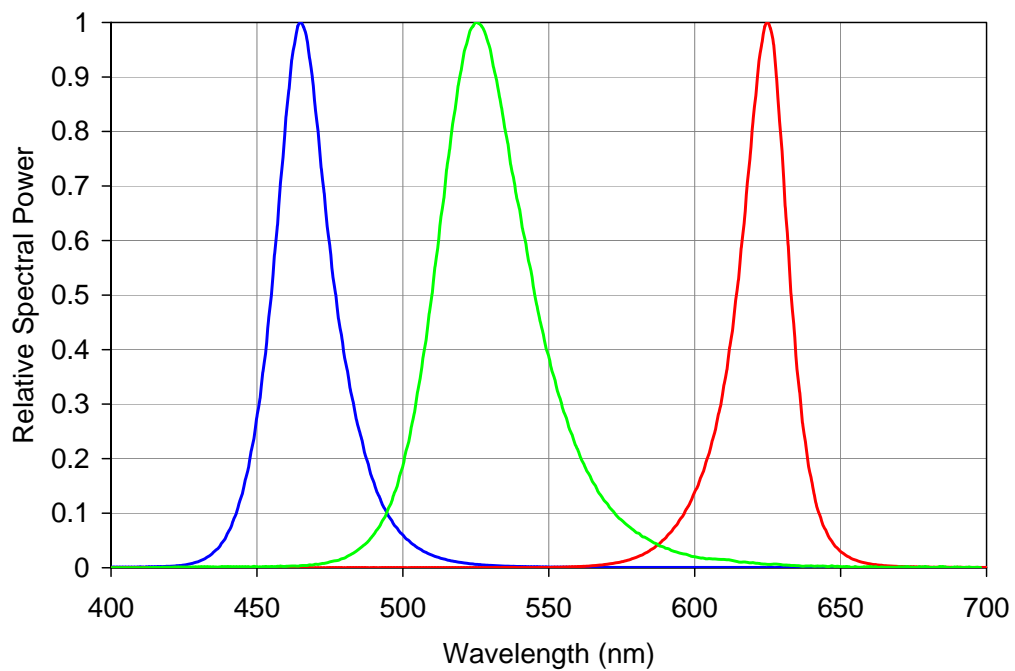

Figure 5: Typical relative spectral power vs. wavelength @  $T_c = 25^\circ\text{C}$ .

## Typical Dominant Wavelength Shift

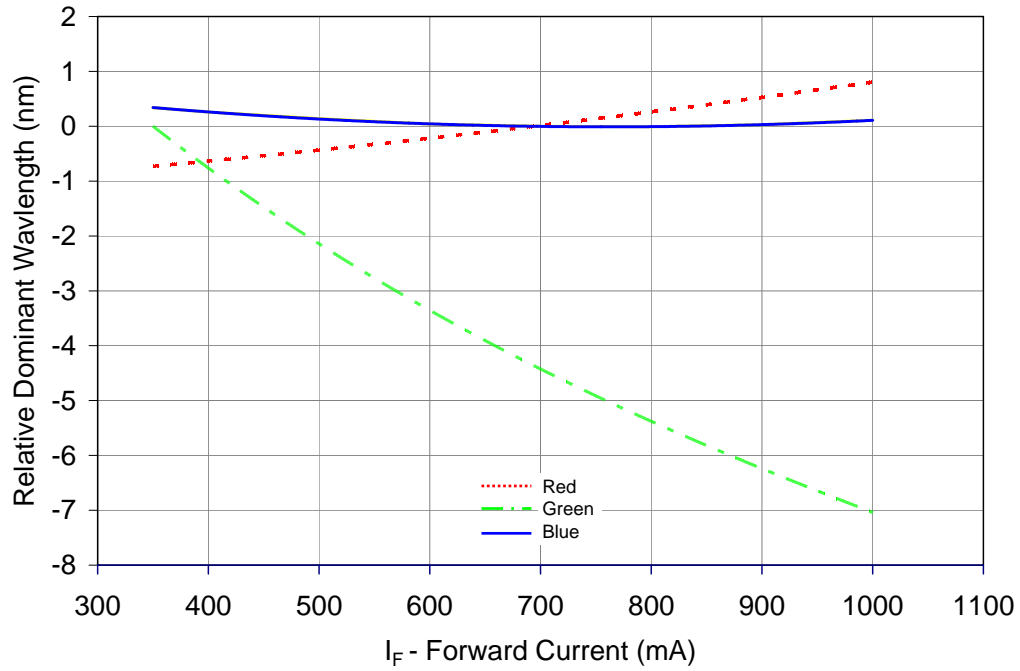

Figure 6: Typical dominant wavelength shift vs. forward current @ T<sub>c</sub> = 25°C.

Notes for Figure 6:

1. Red and Blue dominant wavelength relative to I<sub>F</sub> = 700mA.
2. Green dominant wavelength relative to I<sub>F</sub> = 350mA.

## Dominant Wavelength Shift over Temperature

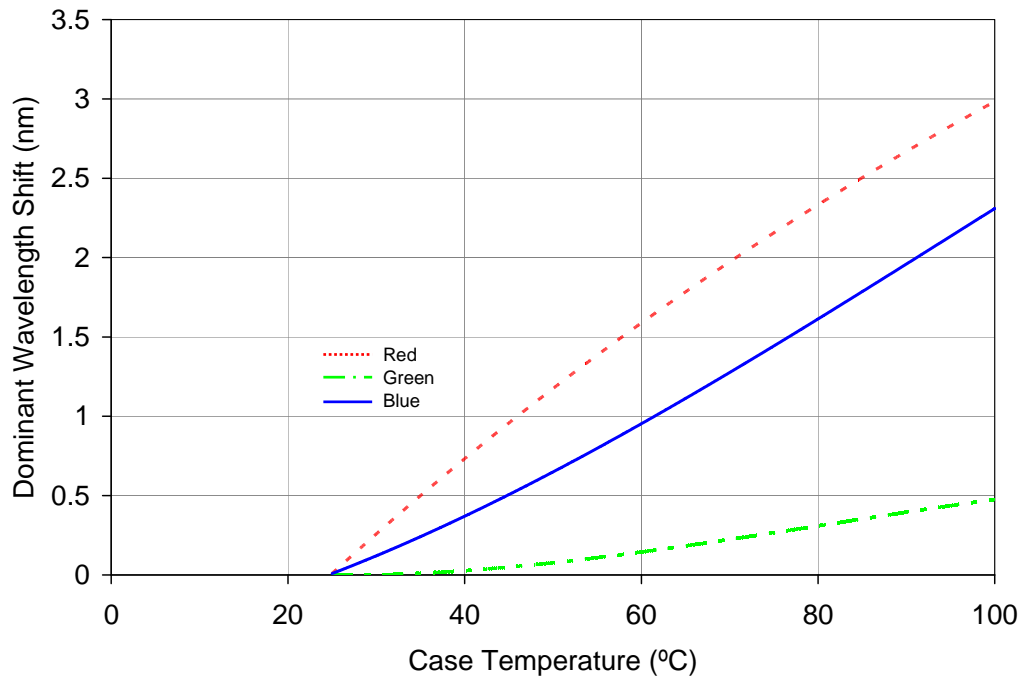

Figure 7: Typical dominant wavelength shift vs. case temperature.

## Typical Relative Light Output

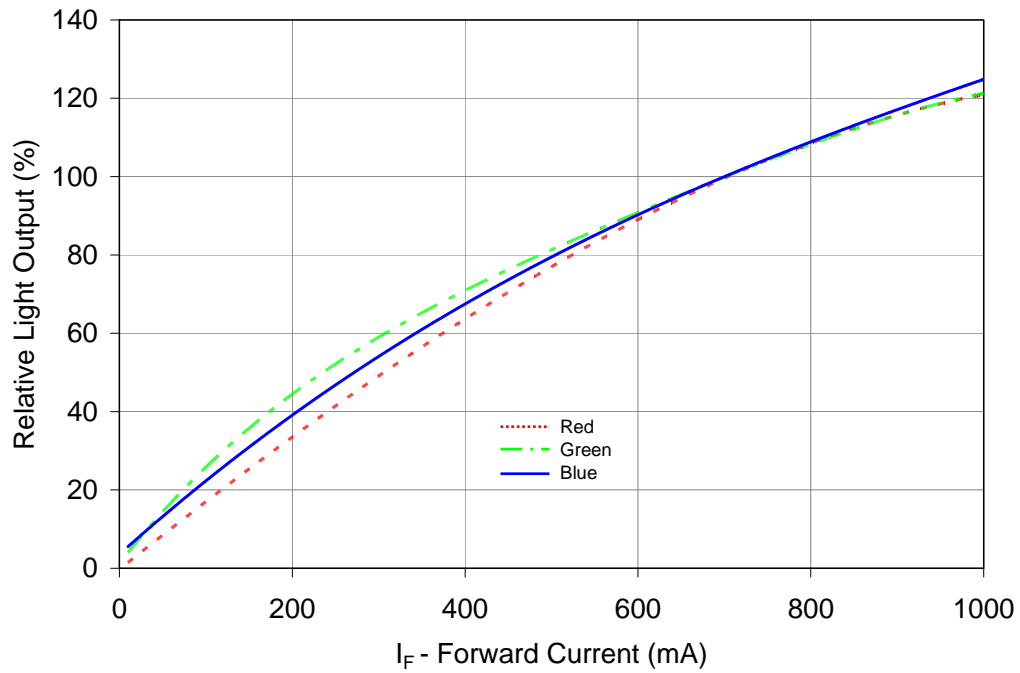

Figure 8: Typical relative light output vs. forward current @  $T_C = 25^\circ\text{C}$ .

## Typical Relative Light Output over Temperature

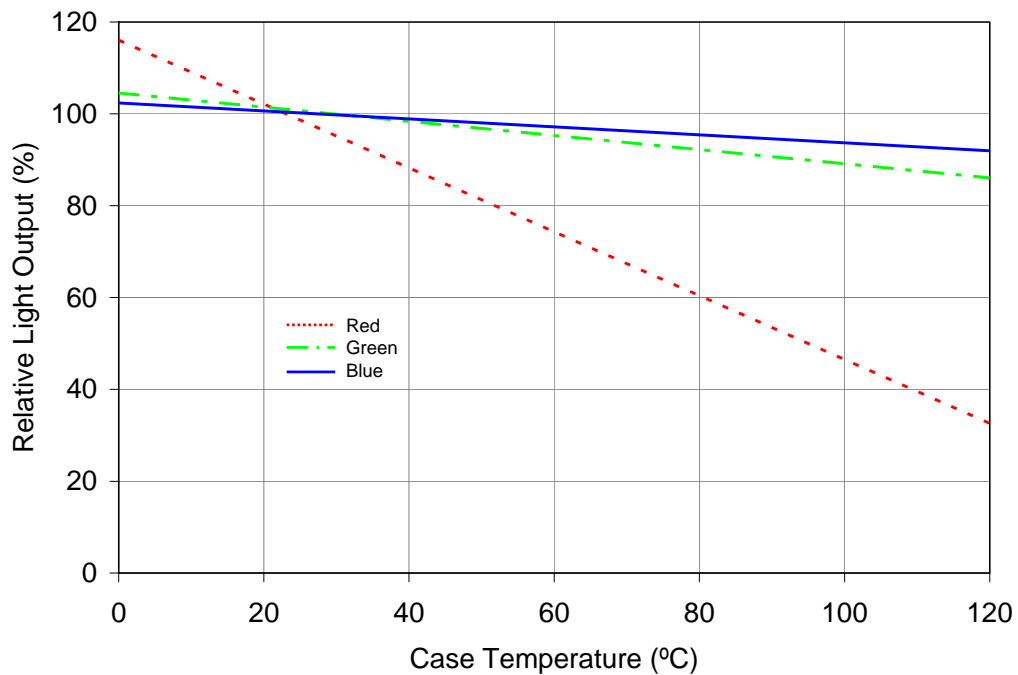

Figure 9: Typical relative light output vs. case temperature.

## Typical Forward Current Characteristics

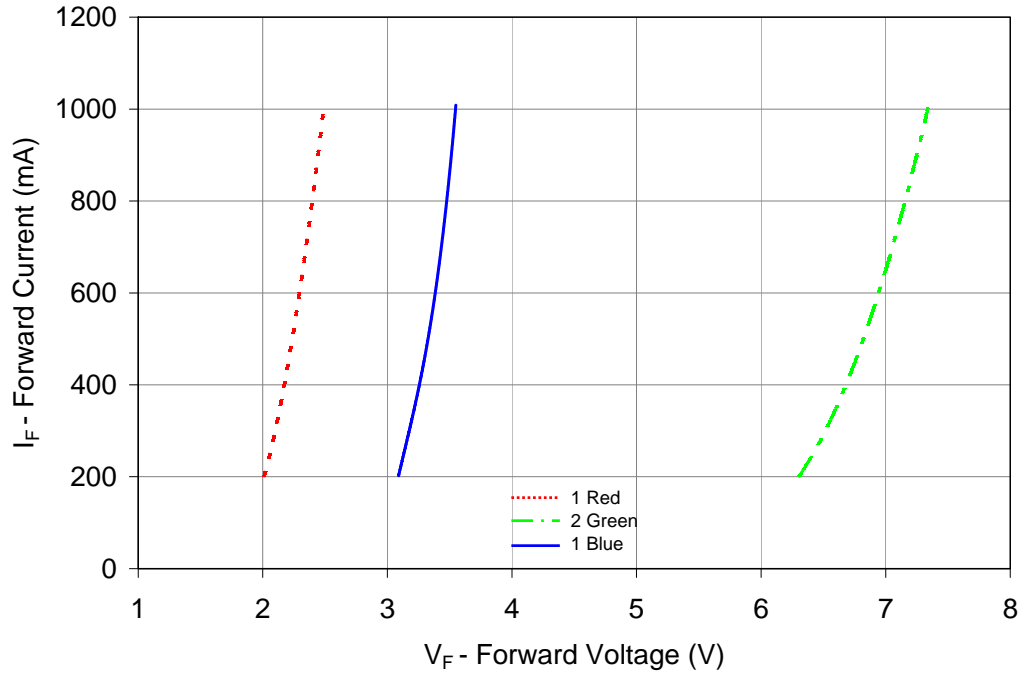

Figure 10: Typical forward current vs. forward voltage @  $T_C = 25^\circ\text{C}$ .

## Current Derating

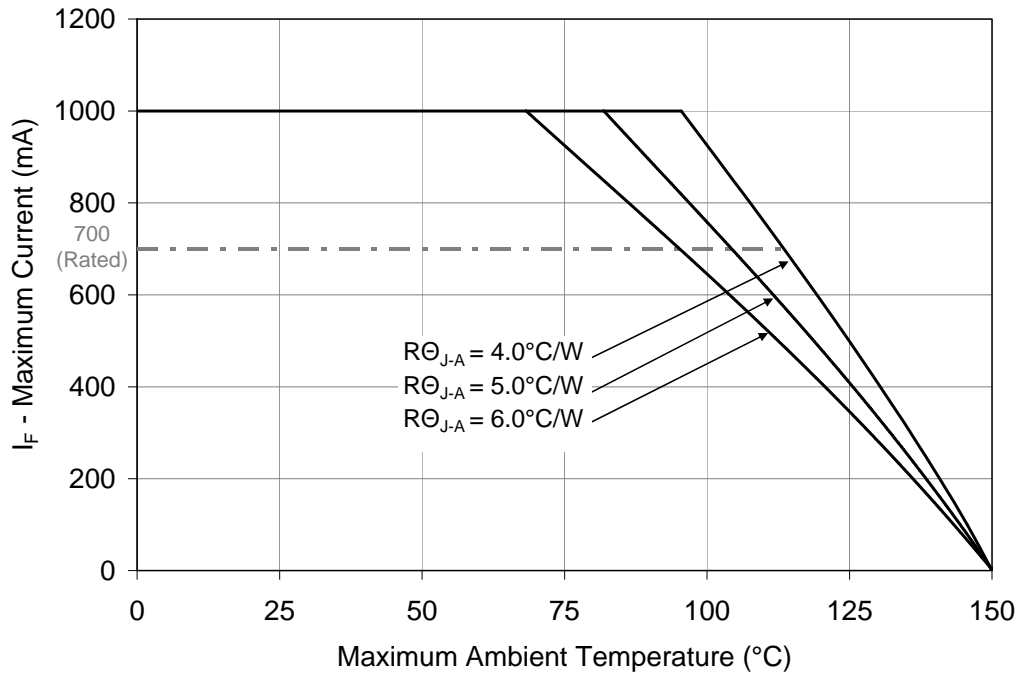

Figure 11: Maximum forward current vs. ambient temperature based on  $T_{J(\text{MAX})} = 150^\circ\text{C}$ .

Notes for Figure 11:

3. Maximum current assumes that all four LED dice are operating concurrently at the same current.
4.  $R_{\theta_{J-C}}$  [Junction to Case Thermal Resistance] for the LZ4-00MC10 is typically  $2.7^\circ\text{C/W}$ .
5.  $R_{\theta_{J-A}}$  [Junction to Ambient Thermal Resistance] =  $R_{\theta_{J-C}} + R_{\theta_{C-A}}$  [Case to Ambient Thermal Resistance].

## Emitter Tape and Reel Specifications (mm)

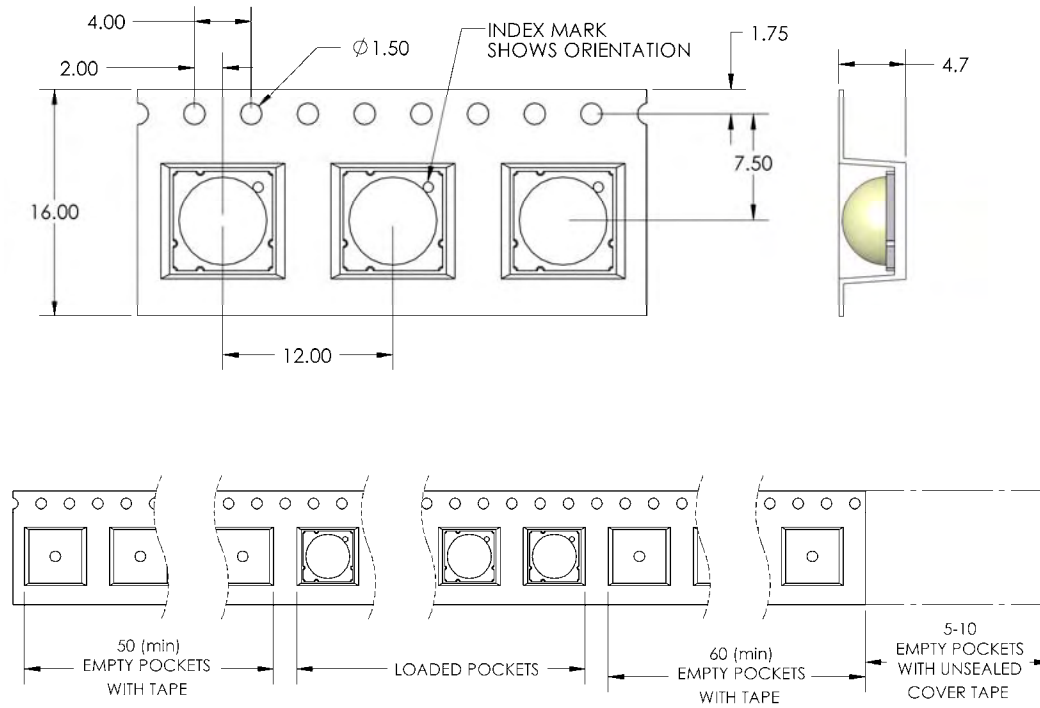

Figure 12: Emitter carrier tape specifications (mm).

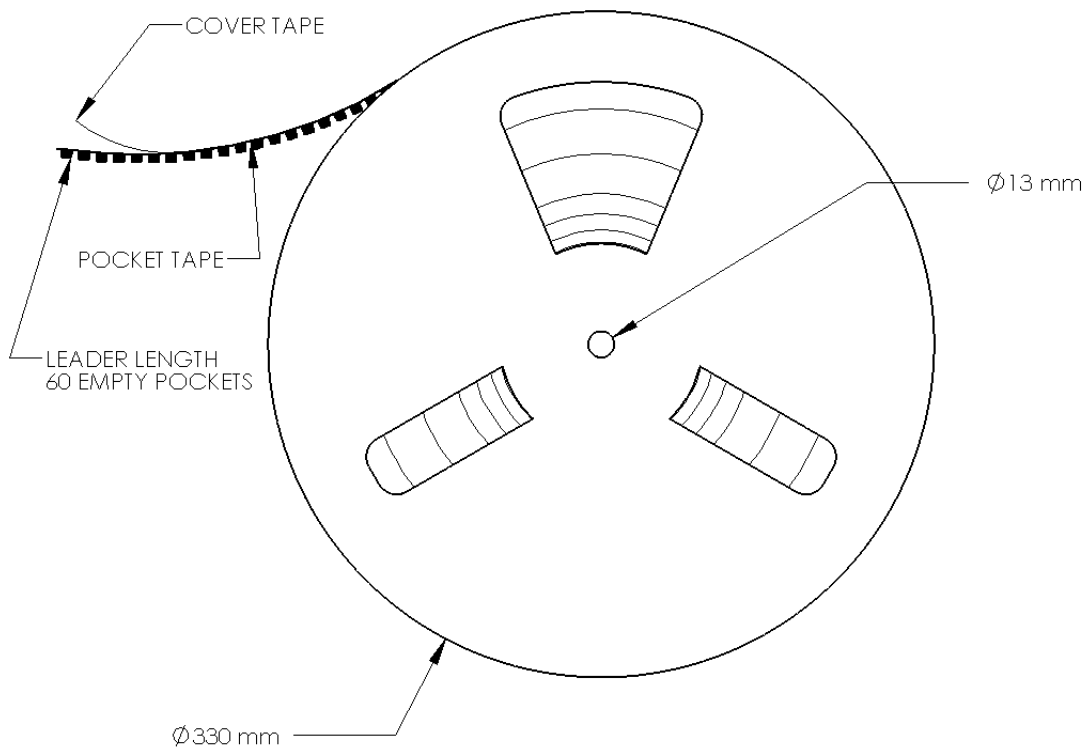

Figure 13: Emitter reel specifications (mm).

## Company Information

The LZ4-00MC10 LED emitter is developed, manufactured and marketed by LedEngin, Inc., located in Santa Clara, CA. LedEngin is a global market leader in advanced high-power LED emitters and light-source modules. LedEngin provides total solutions from 3W to 15W in single packages with ultra-small footprints in all colors from Cool White, Neutral White, Warm White, Red, Green, Blue, Amber, RGB, RGBA, Deep Red, Dental Blue, and UV. LedEngin supports customers to generate solid-state lighting designs that conserve natural resources. LedEngin is focused on differentiated Ultra High-Brightness LED solutions for diverse global markets using its patent-pending package designs and manufacturing processes. LedEngin offers catalog as well as full custom solutions to enable flexible system designs for its customers. LedEngin is dedicated to long-term win-win partnering with its customers and suppliers.

LedEngin reserves the right to make changes to improve performance without notice.

Please contact [Sales@ledengin.com](mailto:Sales@ledengin.com) or (408) 492-0620 for more information.