

High Luminous Efficacy
Green LED Emitter
LZ1-00G103



Key Features

- High Luminous Efficacy 3W Green LED
- Ultra-small foot print – 4.4mm x 4.4mm x 3.2mm
- Surface mount ceramic package with integrated glass lens
- Very high Luminous Flux density
- New industry standard for Lumen Maintenance (>90% at 100,000 Hours)
- Autoclave complaint (JEDEC JESD22-A102-C)
- JEDEC Level 2 for Moisture Sensitivity Level
- Lead (Pb) free and RoHS compliant
- Reflow solderable (up to 6 cycles)
- Emitter available on [Standard](#) or [Miniature](#) MCPCB (optional)

Typical Applications

- Indoor and outdoor Architectural Lighting
- Display Backlighting
- Full Color Displays
- Projectors

Description

The LZ1-00G103 Green LED emitter provides 3W power in an extremely small package. With a 4.4mm x 4.4mm x 3.2mm ultra-small footprint, this package provides exceptional luminous flux per area, up to 4 times greater than competitors' equivalent 3W products. The patent-pending design has unparalleled thermal and optical performance and excellent UV resistance. The high quality materials used in the package are chosen to optimize light output and minimize stresses which results in monumental reliability and lumen maintenance. The robust product design thrives in outdoor applications with high ambient temperatures and high humidity.

Table of Contents

Product Nomenclature	3
IPC/JEDEC Moisture Sensitivity	3
Average Lumen Maintenance Projections	3
Luminous Flux Binning.	4
Dominant Wavelength Binning	4
Forward Voltage Binning	4
Absolute Maximum Ratings	5
Optical Characteristics	5
Electrical Characteristics	5
Mechanical Dimensions	6
Pin-Out	6
Recommended Solder Pad Layout	6
Reflow Soldering Profile	7
Typical Radiation Pattern	8
Typical Relative Spectral Power Distribution	8
Typical Relative Dominant Wavelength Shift	9
Typical Relative Dominant Wavelength Shift over Temperature	9
Typical Relative Light Output	10
Typical Relative Light Output over Temperature	10
Typical Forward Current Characteristics	11
Current Derating Curves	11
Emitter Tape & Reel Specifications	12
Company Information	13

Product Nomenclature

The LZ Series part number designation is defined as follows:



Where:

- A – designates the number of LED die in the package (“1” for 3W)
- B – designates the package level (“0” for Emitter)
- C – designates the radiation pattern (“0” for Lambertian)
- D and E – designate the color (“G1” for Green – 525nm Dominant Wavelength)
- F and G – designate the Power (“03” for 3W typical rating)
- H – designates the Flux bin (See Table 2)
- J and K – designate the Dominant Wavelength bin (see Table 3)
- L – designates the V_F bin (See Table 4)

Ordering information:

For ordering LedEngin products, please reference the base part number. The base part number represents any of the flux, dominant wavelength, or forward voltage bins specified in the binning tables below. For ordering products with special bin selections, please contact a LedEngin sales representative or authorized distributor.

IPC/JEDEC Moisture Sensitivity Level

Table 1 - IPC/JEDEC J-STD-20 MSL Classification:

Level	Soak Requirements					
	Floor Life		Standard		Accelerated	
	Time	Conditions	Time (hrs)	Conditions	Time (hrs)	Conditions
2	1 Year	≤ 30°C/ 60% RH	168 +5/-0	85°C/ 60% RH	n/a	n/a

Notes for Table 1:

1. The standard soak time is the sum of the default value of 24 hours for the semiconductor manufacturer’s exposure time (MET) between bake and bag and the floor life of maximum time allowed out of the bag at the end user of distributor’s facility.

Average Lumen Maintenance Projections

Lumen maintenance generally describes the ability of a lamp to retain its output over time. The useful lifetime for solid state lighting devices (Power LEDs) is also defined as Lumen Maintenance, with the percentage of the original light output remaining at a defined time period.

Based on long-term WHTOL testing, LedEngin projects that the LZ Series will deliver, on average, 90% Lumen Maintenance at 100,000 hours of operation at a forward current of 700 mA. This projection is based on constant current operation with junction temperature maintained at or below 125°C.

Luminous Flux Bins

Table 2:

Bin Code	Minimum Luminous Flux (Φ_V) @ $I_F = 700\text{mA}$ ^[1,2,3] (lm)	Maximum Luminous Flux (Φ_V) @ $I_F = 700\text{mA}$ ^[1,2,3] (lm)	Typical Luminous Flux (Φ_V) @ $I_F = 1000\text{mA}$ ^[3] (lm)
K	75	93	100
L	93	117	126
M	117	146	157

Notes for Table 2:

1. Luminous flux performance guaranteed within published operating conditions.
2. LedEngin maintains a tolerance of $\pm 10\%$ on flux measurements.
3. Future products will have even higher levels of luminous flux performance. Contact LedEngin Sales for updated information.

Dominant Wavelength Bins

Table 3:

Bin Code	Minimum Dominant Wavelength (λ_D) @ $I_F = 350\text{mA}$ ^[1,2,3] (nm)	Maximum Dominant Wavelength (λ_D) @ $I_F = 350\text{mA}$ ^[1,2,3] (nm)
G1	515	520
G2	520	525
G3	525	530
G4	530	535

Notes for Table 3:

1. Dominant wavelength is derived from the CIE 1931 Chromaticity Diagram and represents the perceived hue.
2. LedEngin maintains a tolerance of $\pm 0.5\text{nm}$ on dominant wavelength measurements.
3. Refer to Figure 6 for typical dominant wavelength shift over forward current.

Forward Voltage Bins

Table 4:

Bin Code	Minimum Forward Voltage (V_F) @ $I_F = 700\text{mA}$ ^[1] (V)	Maximum Forward Voltage (V_F) @ $I_F = 700\text{mA}$ ^[1] (V)
F	3.20	3.44
G	3.44	3.68
H	3.68	3.92
J	3.92	4.16
K	4.16	4.40

Notes for Table 4:

1. LedEngin maintains a tolerance of $\pm 0.04\text{V}$ for forward voltage measurements.

Absolute Maximum Ratings

Table 5:

Parameter	Symbol	Value	Unit
DC Forward Current ^[1]	I_F	1000	mA
Peak Pulsed Forward Current ^[2]	I_{FP}	1500	mA
Reverse Voltage	V_R	See Note 3	V
Storage Temperature	T_{stg}	-40 ~ +150	°C
Junction Temperature	T_J	150	°C
Soldering Temperature ^[4]	T_{sol}	260	°C
Allowable Reflow Cycles		6	
Autoclave Conditions ^[5]		121°C at 2 ATM, 100% RH for 168 hours	
ESD Sensitivity ^[6]		> 1,000 V HBM Class 1C JESD22-A114-D	

Notes for Table 5:

- Maximum DC forward current is determined by the overall thermal resistance and ambient temperature. Follow the curves in Figure 11 for current derating.
- Pulse forward current conditions: Pulse Width \leq 10msec and Duty cycle \leq 10%.
- LEDs are not designed to be reverse biased.
- Solder conditions per JEDEC 020D. See Reflow Soldering Profile Figure 3.
- Autoclave Conditions per JEDEC JESD22-A102-C.
- LedEngin recommends taking reasonable precautions towards possible ESD damages and handling the LZ1-00G103 in an electrostatic protected area (EPA). An EPA may be adequately protected by ESD controls as outlined in ANSI/ESD S6.1.

Optical Characteristics @ $T_C = 25^\circ\text{C}$

Table 6:

Parameter	Symbol	Typical	Unit
Luminous Flux (@ $I_F = 700\text{mA}$)	Φ_V	115	lm
Luminous Flux (@ $I_F = 1000\text{mA}$)	Φ_V	140	lm
Dominant Wavelength (@ $I_F = 350\text{mA}$) ^[1]	λ_D	525	nm
Viewing Angle ^[2]	$2\Theta_{1/2}$	80	Degrees
Total Included Angle ^[3]	$\Theta_{0.9}$	90	Degrees

Notes for Table 6:

- Refer to Figure 6 for typical dominant wavelength shift over forward current.
- Viewing Angle is the off axis angle from emitter centerline where the luminous intensity is $\frac{1}{2}$ of the peak value.
- Total Included Angle is the total angle that includes 90% of the total luminous flux.

Electrical Characteristics @ $T_C = 25^\circ\text{C}$

Table 7:

Parameter	Symbol	Typical	Unit
Forward Voltage (@ $I_F = 700\text{mA}$)	V_F	3.5	V
Forward Voltage (@ $I_F = 1000\text{mA}$)	V_F	3.7	V
Temperature Coefficient of Forward Voltage	$\Delta V_F / \Delta T_J$	-3.3	mV/°C
Thermal Resistance (Junction to Case)	$R\Theta_{J-C}$	11	°C/W

Mechanical Dimensions (mm)

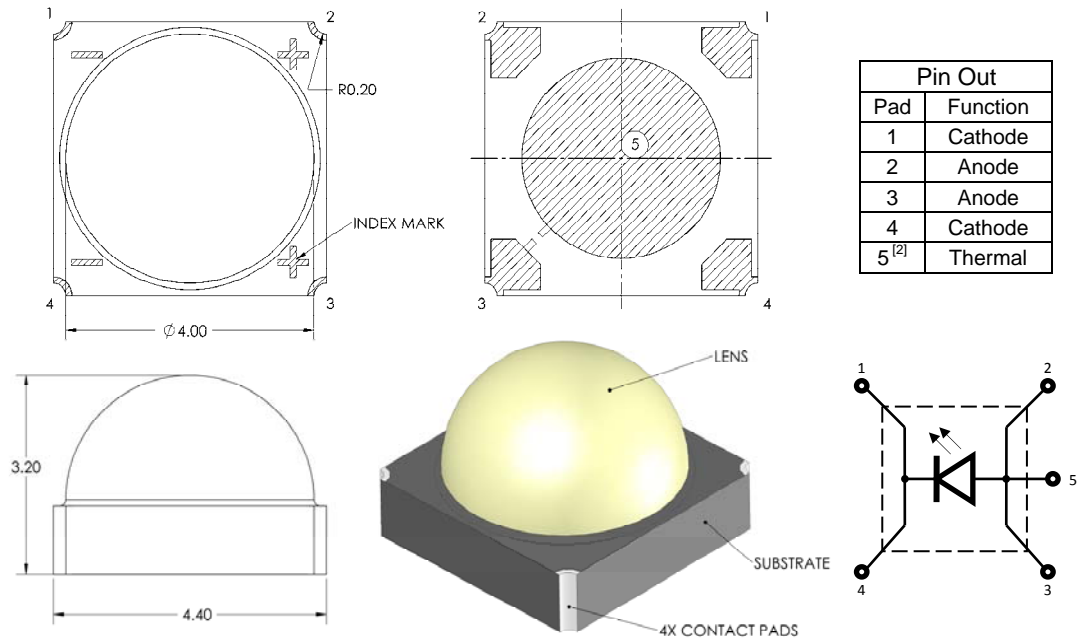

Figure 1: Package outline drawing.

Notes for Figure 1:

1. Unless otherwise noted, the tolerance = ± 0.20 mm.
2. Thermal contact, Pad 5, is electrically connected to the Anode, Pads 2 and 3. Do not connect any pad to the thermal contact, Pad # 5. When mounting the LZ1-00G103 onto a MCPCB, by default its dielectric layer provides for the necessary electrical insulation in between all contact pads. LedEngin offers [LZ1-10G103](#) [Option 1] and [LZ1-30G103](#) [Option 3] MCPCB options which provide for electrical insulation between all contact pads. Please refer to Application Note MCPCB Option 1 and Option 3, or contact a LedEngin sales representative for more information.

Recommended Solder Pad Layout (mm)

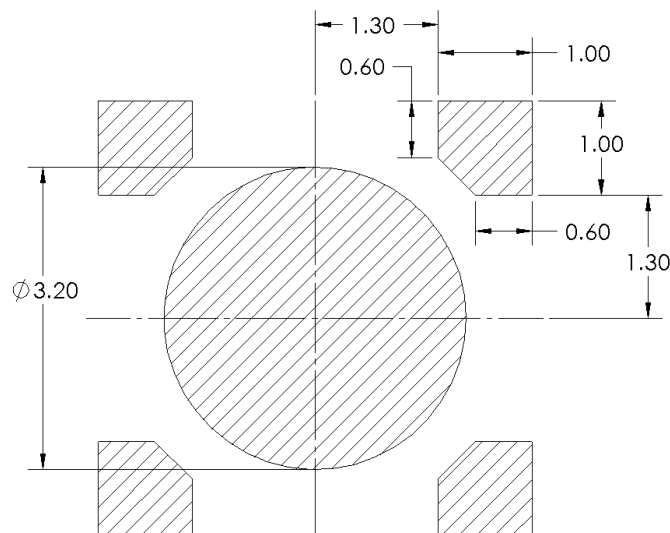

Figure 2: Recommended solder mask opening (hatched area) for anode, cathode, and thermal pad.

Note for Figure 2:

1. Unless otherwise noted, the tolerance = ± 0.20 mm.

Reflow Soldering Profile

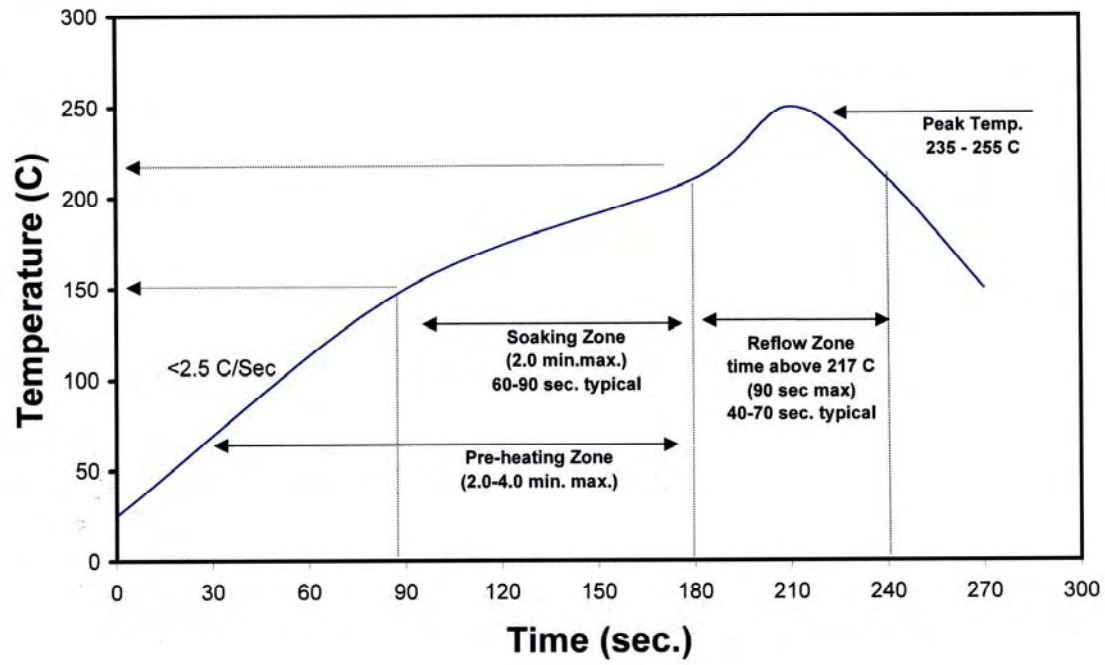

Figure 3: Reflow soldering profile for lead free soldering.

Typical Radiation Pattern

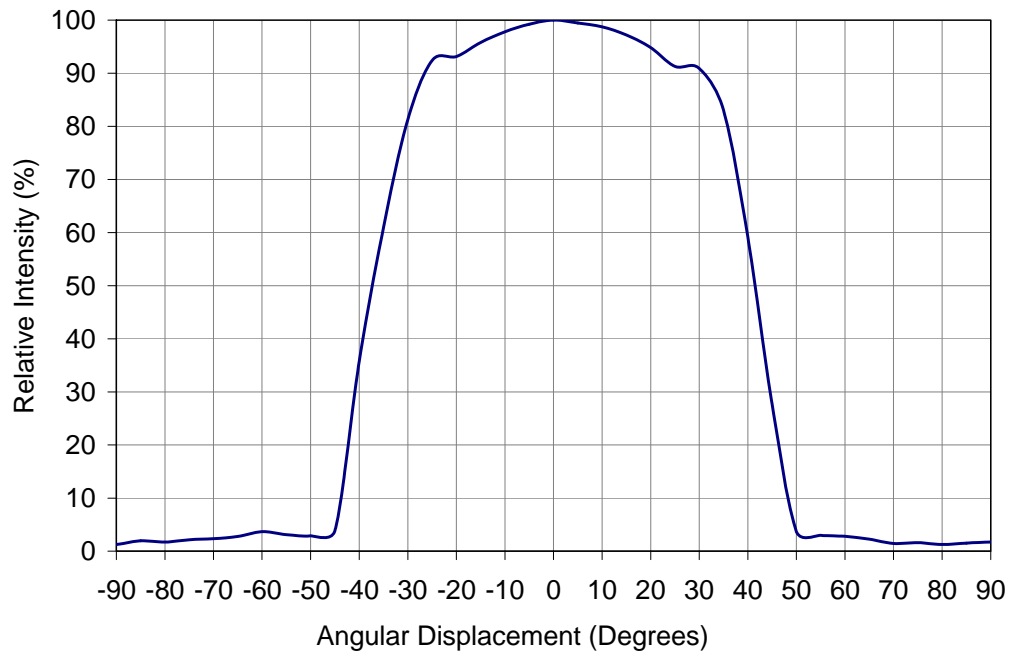

Figure 4: Typical representative spatial radiation pattern @ $T_c = 25^\circ\text{C}$.

Typical Relative Spectral Power Distribution

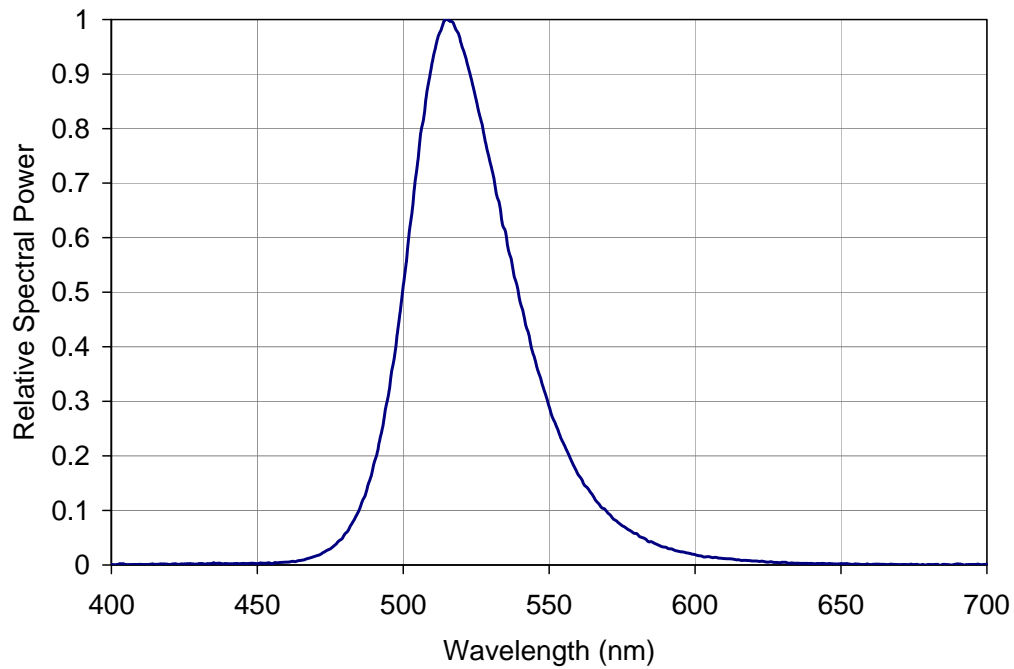

Figure 5: Relative spectral power vs. wavelength @ $I_f = 350\text{mA}$ and $T_c = 25^\circ\text{C}$.

Typical Relative Dominant Wavelength Shift

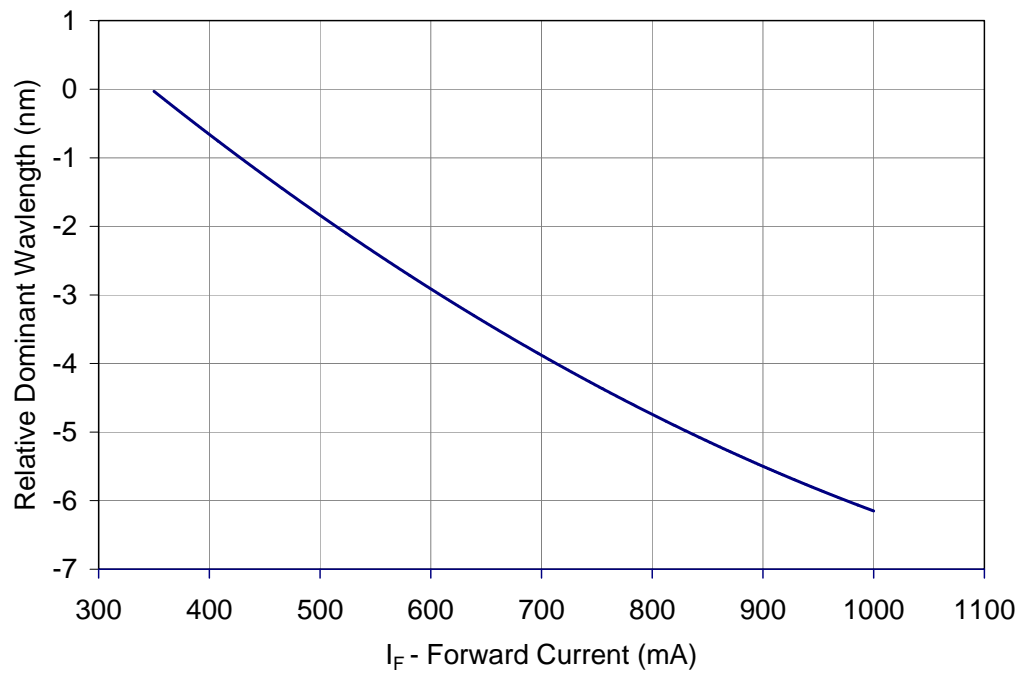

Figure 6: Typical dominant wavelength shift vs. forward current @ T_c = 25°C.

Typical Relative Dominant Wavelength Shift over Temperature

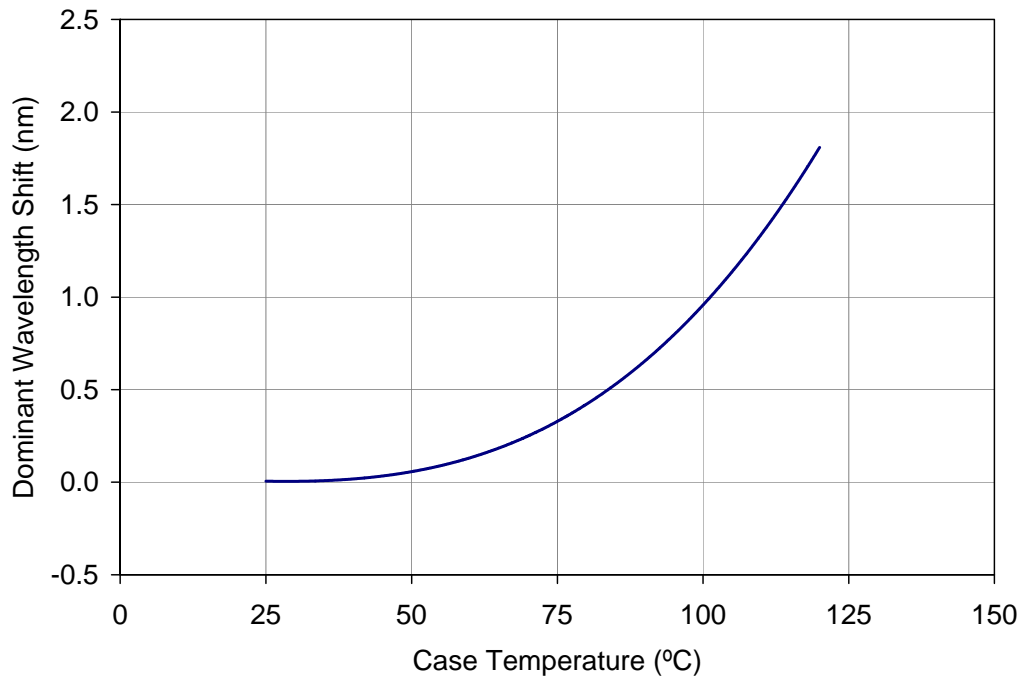

Figure 7: Typical dominant wavelength shift vs. case temperature.

Typical Relative Light Output

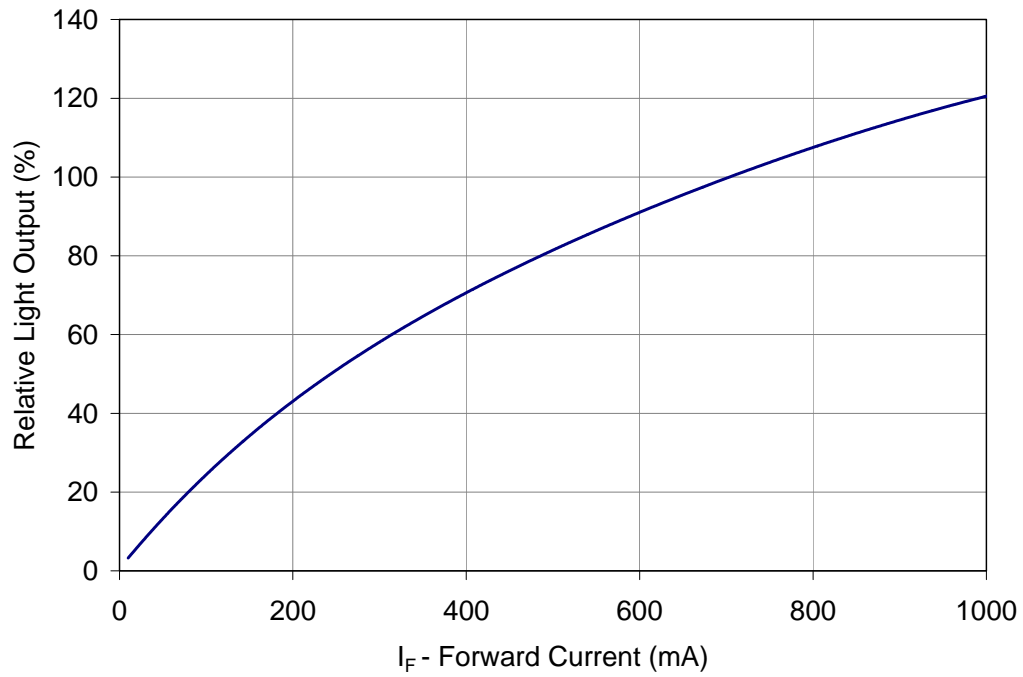

Figure 8: Typical relative light output vs. forward current @ T_c= 25°C.

Typical Relative Light Output over Temperature

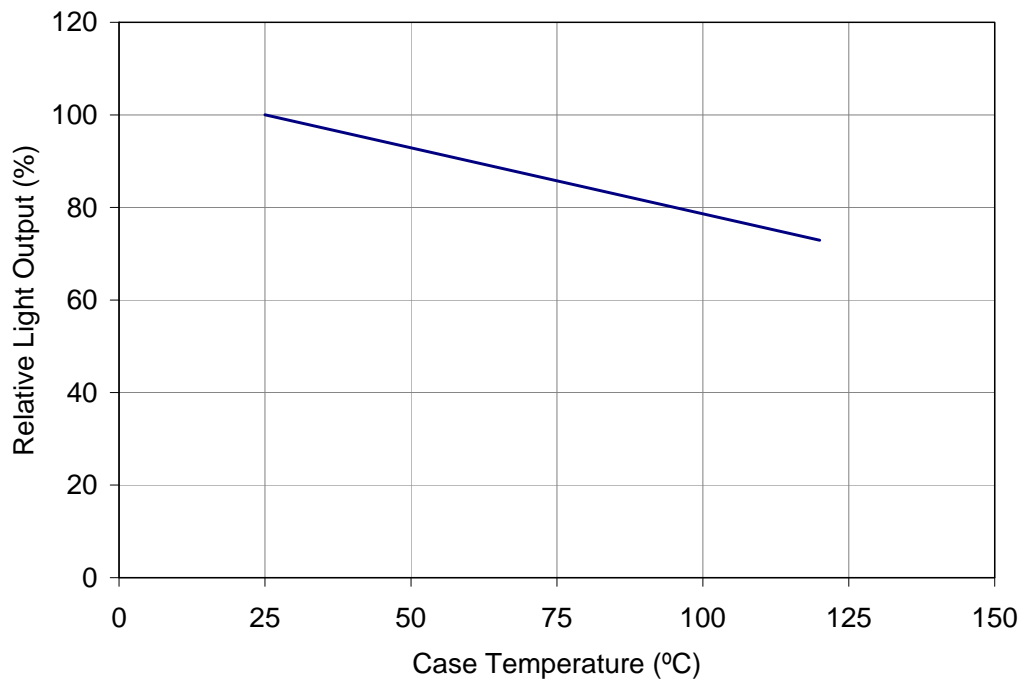

Figure 9: Typical relative light output vs. case temperature.

Typical Forward Current Characteristics

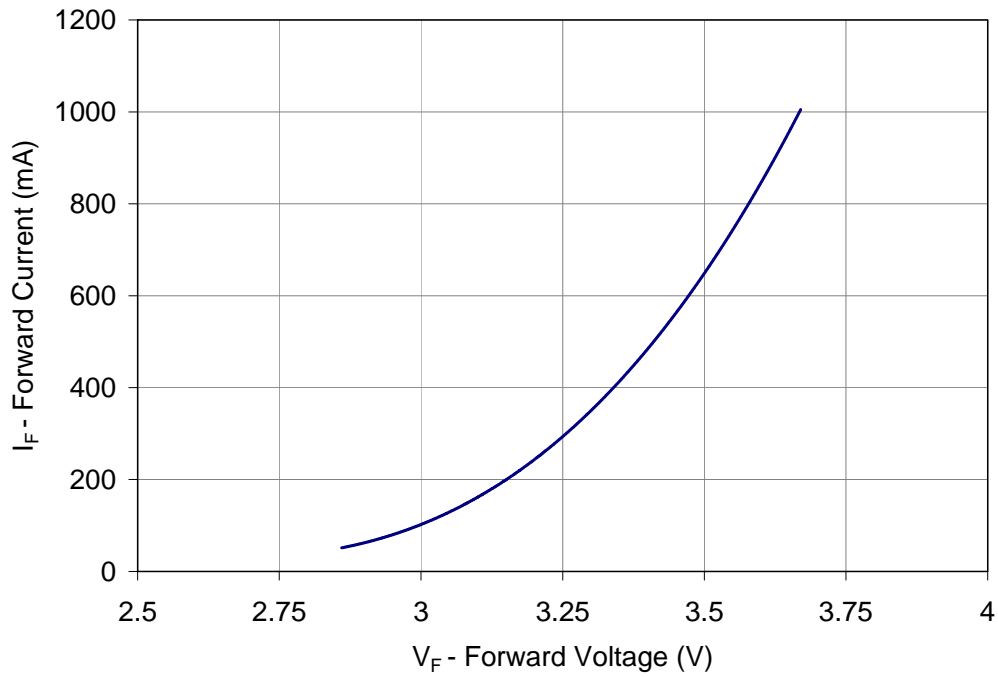

Figure 10: Typical forward current vs. forward voltage @ $T_C = 25^\circ\text{C}$.

Current Derating

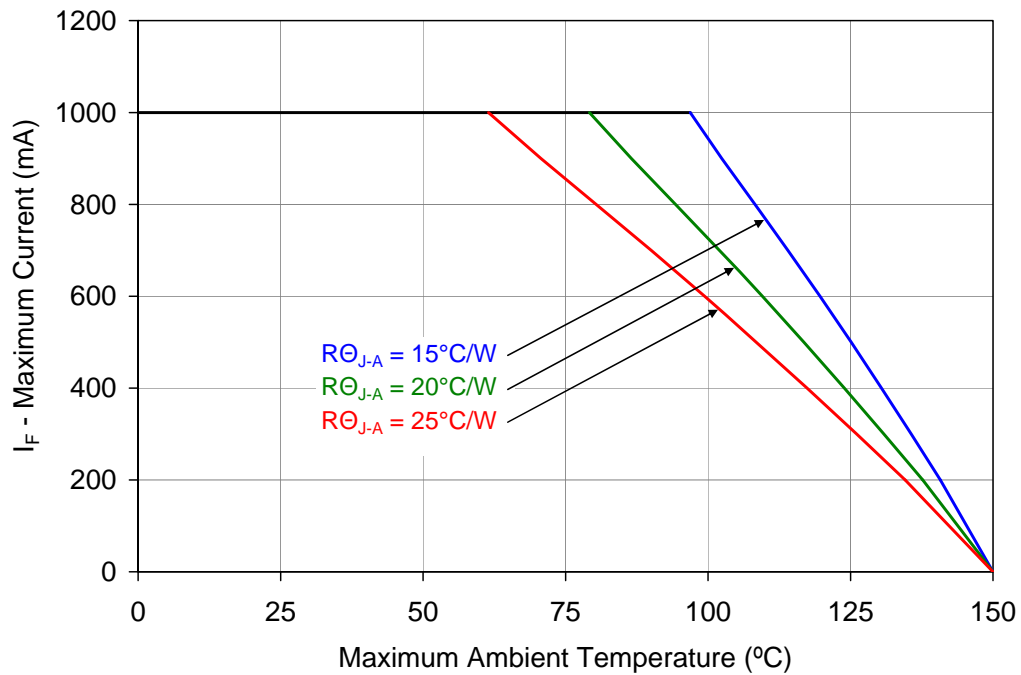

Figure 11: Maximum forward current vs. ambient temperature based on $T_{J(\text{MAX})} = 150^\circ\text{C}$.

Notes for Figure 11:

1. $R\theta_{J-C}$ [Junction to Case Thermal Resistance] for the LZ1-00G103 is typically 11°C/W .
2. $R\theta_{J-A}$ [Junction to Ambient Thermal Resistance] = $R\theta_{J-C}$ + $R\theta_{C-A}$ [Case to Ambient Thermal Resistance].

Emitter Tape and Reel Specifications (mm)

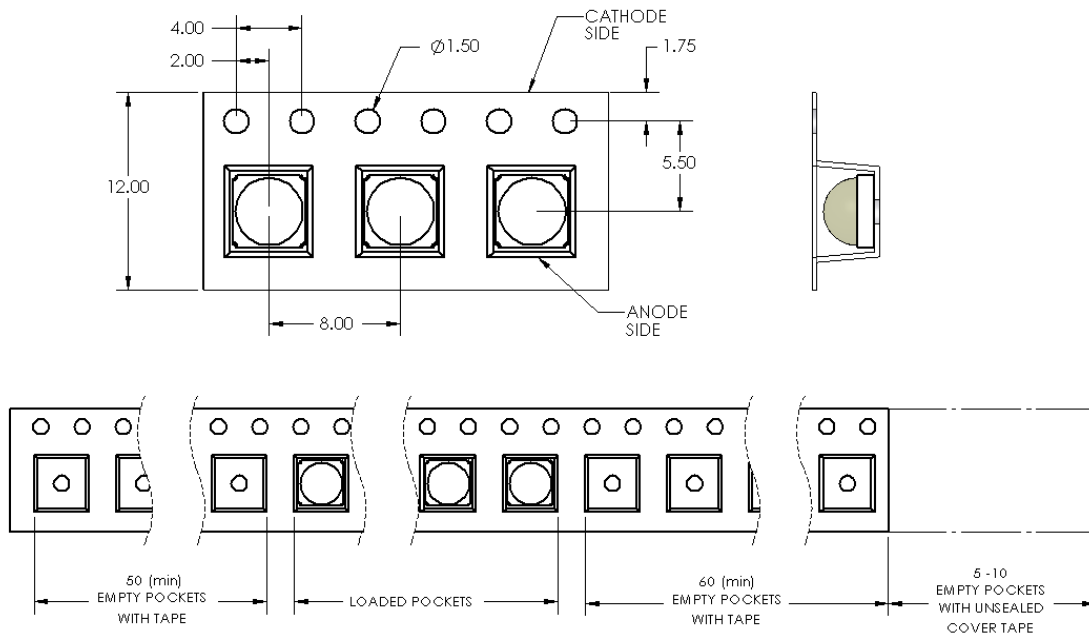

Figure 12: Emitter carrier tape specifications (mm).

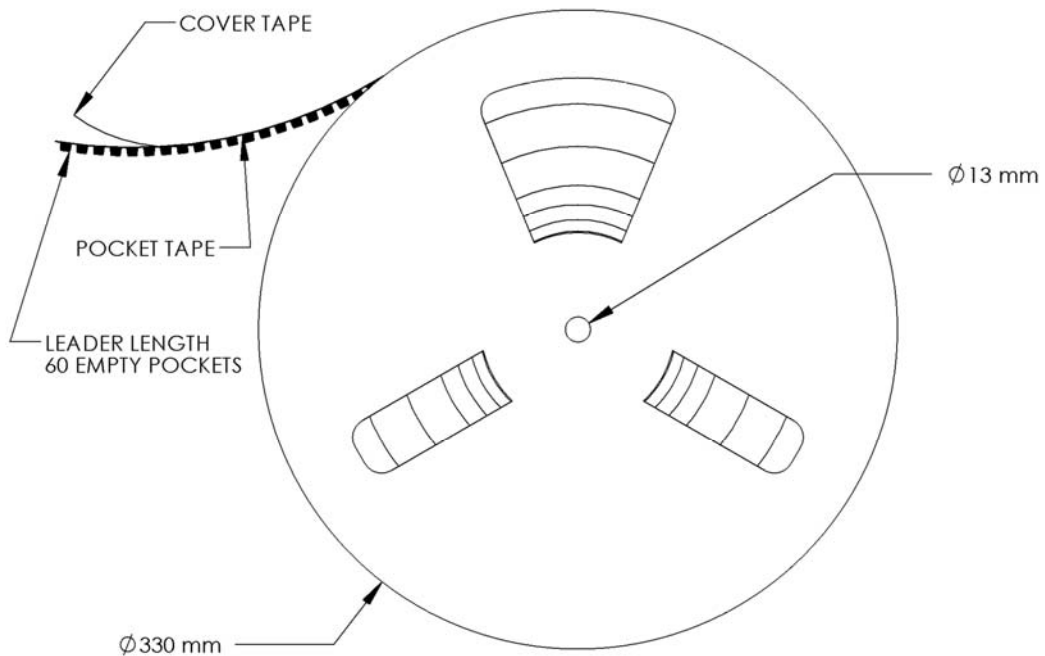

Figure 13: Emitter reel specifications (mm).

Company Information

The LZ1-00G103 LED emitter is developed, manufactured, and marketed by LedEngin, Inc., located in Santa Clara, CA. LedEngin is a global leader in advanced high-power LED emitters and light-source modules. LedEngin provides total solutions from 3W to 15W in single packages with ultra-small footprints in all colors from Cool White, Neutral White, Warm White, Red, Green, Blue, Amber, RGB, RGBA, Deep Red, Dental Blue and UV. LedEngin supports customers to generate solid-state lighting designs that conserve natural resources. LedEngin is focused on differentiated Ultra High-Brightness LED solutions for diverse global markets using its patent-pending package designs and manufacturing processes. LedEngin offers catalog as well as full custom solutions to enable flexible system designs for its customers. LedEngin is dedicated to long-term win-win partnering with its customers and suppliers.

LedEngin reserves the right to make changes to improve performance without notice.

Please contact Sales@ledengin.com or (408) 492-0620 for more information.